

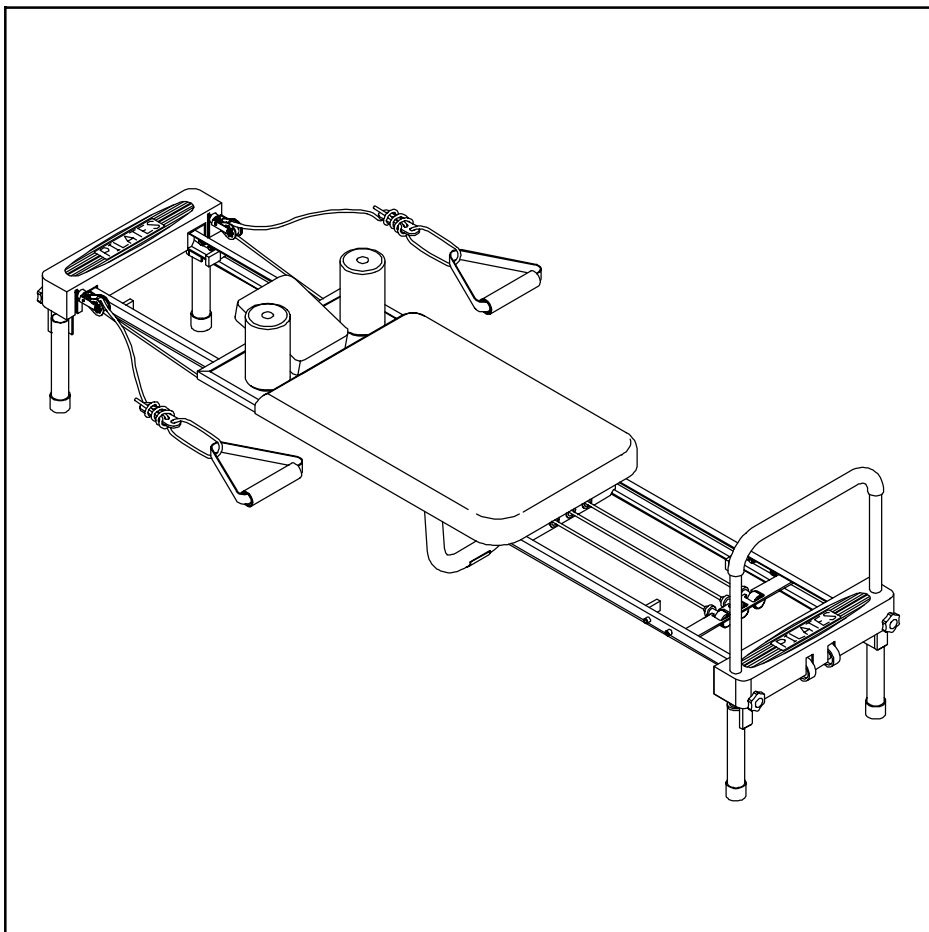

PILATES PERFORMER®

Owner's Manual



⚠ WARNING ⚠

Exercise can present a health risk. Consult a physician before beginning any exercise program with this equipment. If you feel faint or dizzy, immediately discontinue use of this equipment. Serious bodily injury can occur if this equipment is not assembled and used correctly. Serious bodily injury can also occur if all instructions are not followed. Keep others and pets away from equipment when in use. Always make sure all bolts and nuts are tightened prior to each use. Follow all safety instructions in this manual.

When calling for parts or service, please specify the following number.

55-4290

Pat. No. D382,319

**Other Patents Applied
and Are Pending**

MADE IN CHINA

**Product May Vary Slightly
From Pictured.**

CAUTION:

Weight on this product should not exceed 300 lbs.

This Product is Produced Exclusively by



2040 N. Alliance, Springfield, MO 65803

Customer Service Number

1 (800) 375-7520

www.staminaproducts.com

TABLE OF CONTENTS

	Page
Safety Instructions	2
Before You Begin	4
Hardware Illustrations	5
Assembly Instructions	6
Usage Information	9
Conditioning Guidelines	10
Warm-up and Cool-Down	11
Product Parts Drawing	12
Parts List	13
Warranty	15
Notes	16
Fax/Mail Ordering Form	18

SAFETY INSTRUCTIONS

WARNING: To reduce the risk of serious injury, read the following Safety Instructions before using the **PILATES PERFORMER JP** .

1. Use the **PILATES PERFORMER JP** only on a level surface.
2. Make sure that all six (6) **LOCKING KNOBS(27)** are securely tightened before using the **PILATES PERFORMER JP** .
3. Remove the **LOCKING PIN(22)** which locks the **CUSHION ASSEMBLY(7)** in place before attaching the **TENSION CORDS(9)** to the slots.
4. Wear appropriate clothing when exercising; do not wear loose clothing that could become caught in the **PILATES PERFORMER JP** .
5. Keep small children and pets away from the **PILATES PERFORMER JP** at all times including while using, folding, unfolding, or assembling the **PILATES PERFORMER JP** .
6. The **PILATES PERFORMER JP** should not be used by persons weighing more than 300 lbs.
7. The **PILATES PERFORMER JP** should be used by only one person at a time.
8. Be careful to maintain your balance while using, mounting, dismounting, folding, unfolding or assembling the **PILATES PERFORMER JP**, loss of balance may result in a fall and serious bodily injury.
9. When folding or unfolding the **PILATES PERFORMER JP**, keep all children away from the **PILATES PERFORMER JP** and make sure your hands are clear of any folding or pinch point.
10. Use the **PILATES PERFORMER JP** only as described in the manual.

WARNING: Before starting any exercise or conditioning program you should consult with your personal physician to see if you require a complete physical exam. This is especially important if you are over the age of 35, have never exercised before, are pregnant, or suffer from any illness. **READ AND FOLLOW THE SAFETY INSTRUCTIONS. FAILURE TO FOLLOW THESE INSTRUCTIONS CAN RESULT IN SERIOUS BODILY INJURY.**

CALL US FIRST



CUSTOMER SERVICE NUMBER
1 (800) 375-7520

**THANK YOU FOR PURCHASING THE
PILATES PERFORMER JP**

To help you get started, we have pre-assembled most of your PILATES PERFORMER JP at the factory with the exception of those few parts left unassembled for shipping purposes. Simply follow the few assembly instructions set forth in this manual. Within a few minutes you will be getting your body into shape and on your way to achieving a happier and healthier lifestyle.

Should you have any questions,
please call our Customer Service Department toll-free number,
1 (800) 375-7520
Monday - Friday, 8:00 A.M. - 5:00 P.M., Central Time.

BEFORE YOU BEGIN

Thank you for choosing the **PILATES PERFORMER JP**. We take great pride in producing this quality product and hope it will provide many hours of quality exercise to make you feel better, look better and enjoy life to its fullest.

Yes, it's a proven fact that a regular exercise program can improve your physical and mental health. Too often, our busy lifestyles limit our time and opportunity to exercise. The **PILATES PERFORMER JP** provides a convenient and simple method to begin your assault on getting your body in shape and achieving a happier and healthier lifestyle.

Before reading further, please review the drawing below and familiarize yourself with the parts that are labeled.

Read this manual carefully before using the **PILATES PERFORMER JP**.

Although Stamina tries to manufacture its products with the finest materials and uses the highest standards of manufacturing, occasionally a part that does not fit, is the incorrect size, or is otherwise inappropriate is found. Even with the highest inspection and quality controls in place these things will happen occasionally. Please do not return the product. For your convenience, Stamina has a Customer Service Department with a toll-free number. If a part is missing, does not fit, is the incorrect size, or is otherwise inappropriate, please call 1 (800) 375-7520 (in the U.S.) between 8:00 A.M. and 5:00 P.M. Central Time, Monday through Friday. Our operators will be able to assist you with your problem and the parts will be mailed directly to your house.

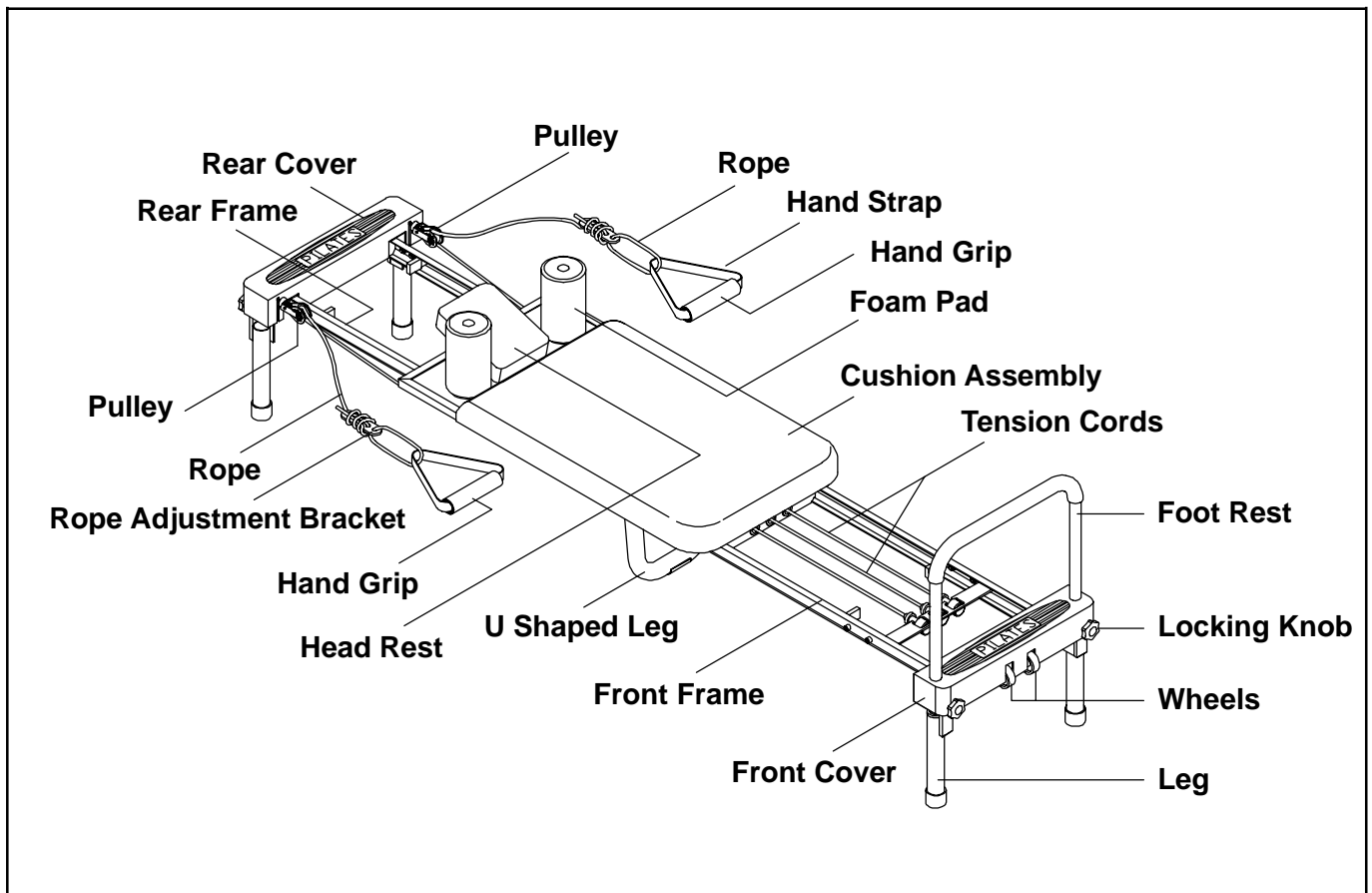

THE FOLLOWING TOOLS ARE REQUIRED FOR ASSEMBLY :

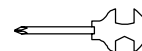

Combination Wrench



Socket Wrench

HARDWARE ILLUSTRATIONS

This chart is provided to help identify some of the small parts used in the assembly of this product. This sheet may not include all the hardware needed to assemble your product. It is intended to be used as a guide to help simplify your assembly process.

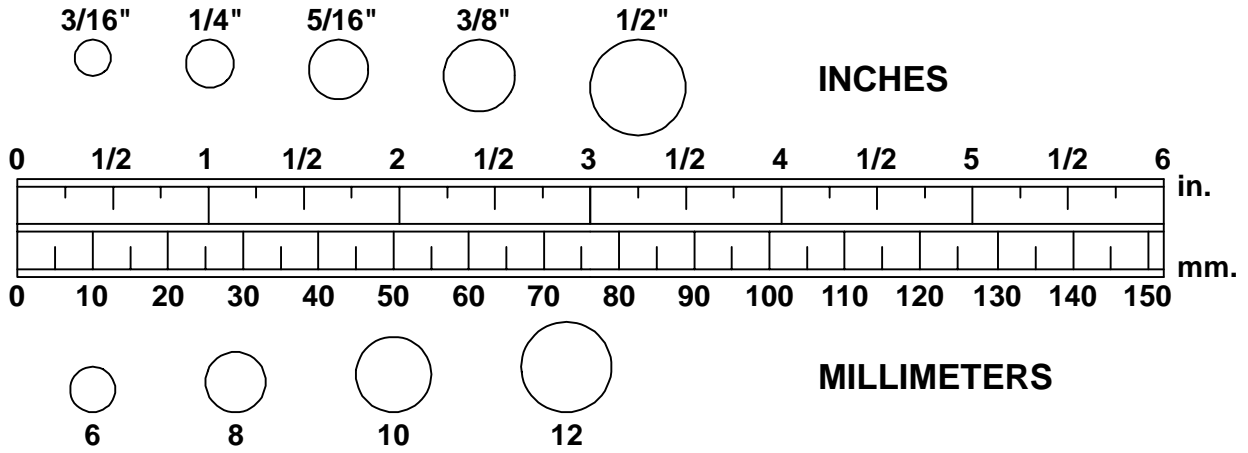

Place washers, the end of bolts or screws on the circles to check for the correct size. Use the small scale to check the sizes of bolts and screws.

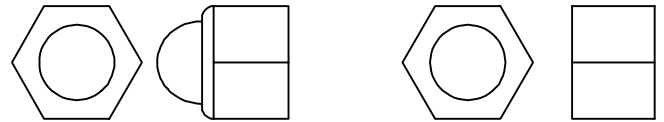

Acorn Nut

Standard Nut

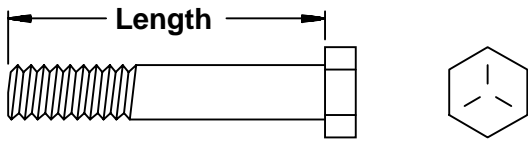

Hex Head Bolt

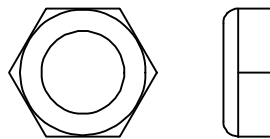

Thin Nylock Nut

Nylock Nut

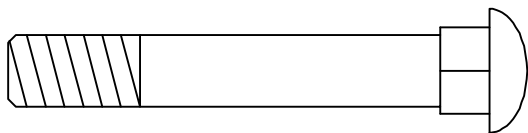

Carriage Bolt

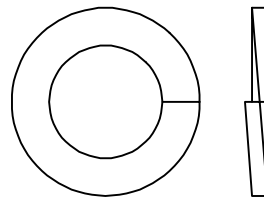

Lock Washer

Flat Washer

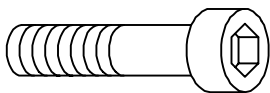

Socket Head Screw

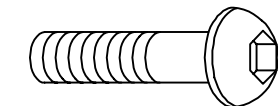

Button Head Screw

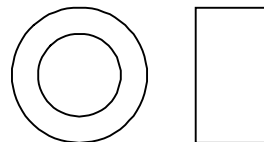

Spacer

Nut Cap

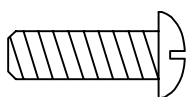

Round Head Screw

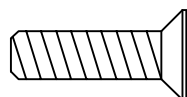

Flat Head Screw

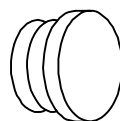

Round Plug

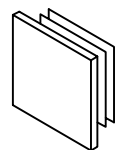

Square Plug

ASSEMBLY INSTRUCTIONS

Place all parts from the box in a cleared area and position them on the floor in front of you. Remove all packing materials from your area and place them back into the box. Do not dispose of the packing materials until assembly is completed. Read each step carefully before beginning. If you are missing a part please call our toll-free number for assistance **1 (800) 375-7520** or e-mail us at: **parts@staminaproducts.com**

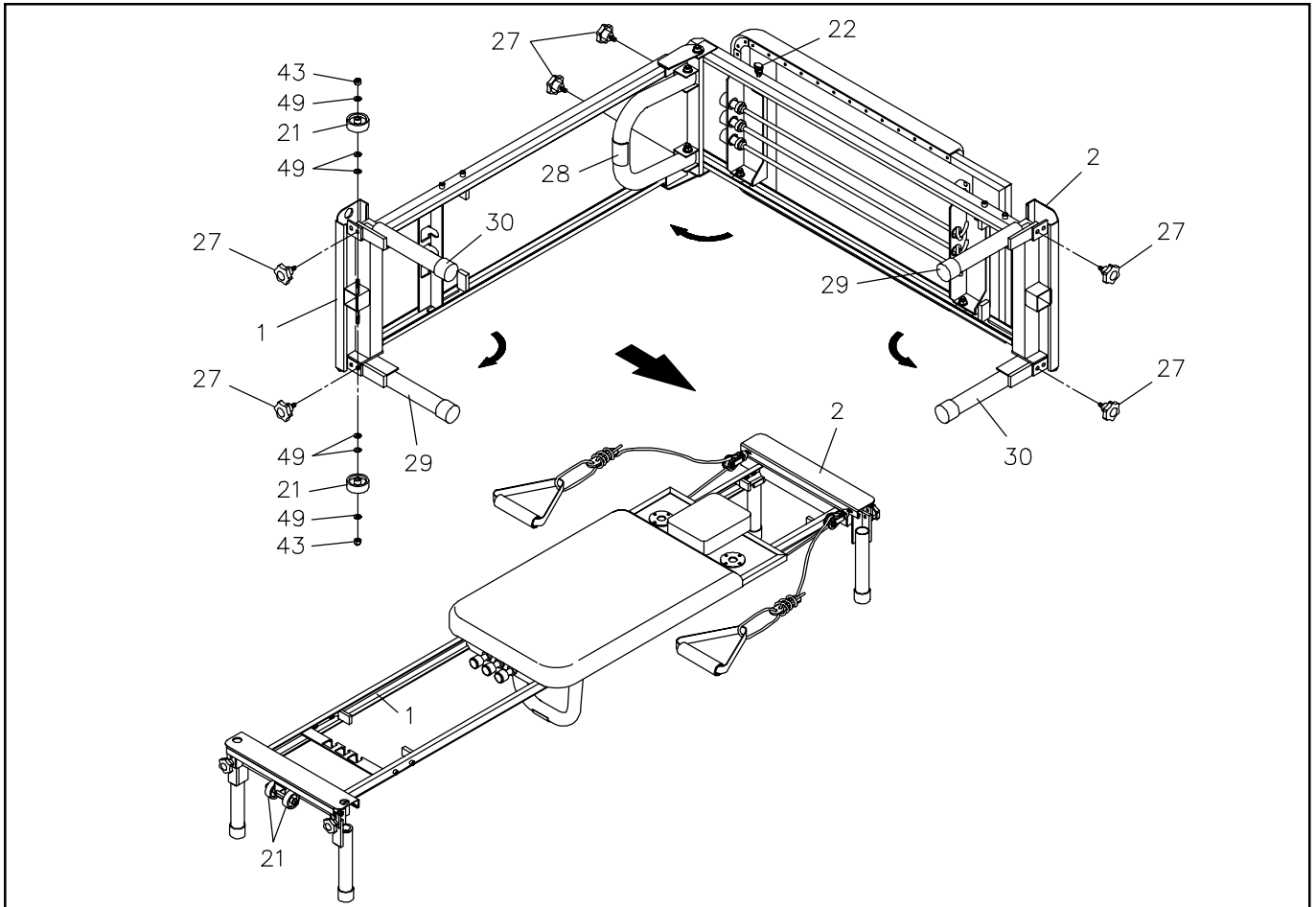

STEP 1

Set the **PILATES PERFORMER JP** on the floor on its side, with the **LOCKING PIN(22)** side upward. Make sure the **LOCKING PIN(22)** locks the **CUSHION ASSEMBLY(7)** properly. Unfold the **MAIN FRAME ASSEMBLY** half way as shown in the illustration.

STEP 2

Swing the **LEGS(29, 30)** and the **U SHAPED LEG(28)** into position. Lock the legs onto the **FRONT** and **REAR FRAME(1, 2)** with the **LOCKING KNOBS(27)**. Attach the **WHEELS(21)** onto the **FRONT FRAME(1)** with **WASHERS(M8)(49)** and **NYLOCK NUTS(M8)(43)**.

WARNING: Make sure that all six (6) locking knobs are securely tightened before using the **PILATES PERFORMER JP** .

STEP 3

Unfold your **PILATES PERFORMER JP** until it is fully extended. Place the **PILATES PERFORMER JP** in the upright position.

WARNING: When folding or unfolding the **PILATES PERFORMER JP**, keep all children away from the **PILATES PERFORMER JP** and make sure your hands are clear of any folding or pinch point.

ASSEMBLY INSTRUCTIONS

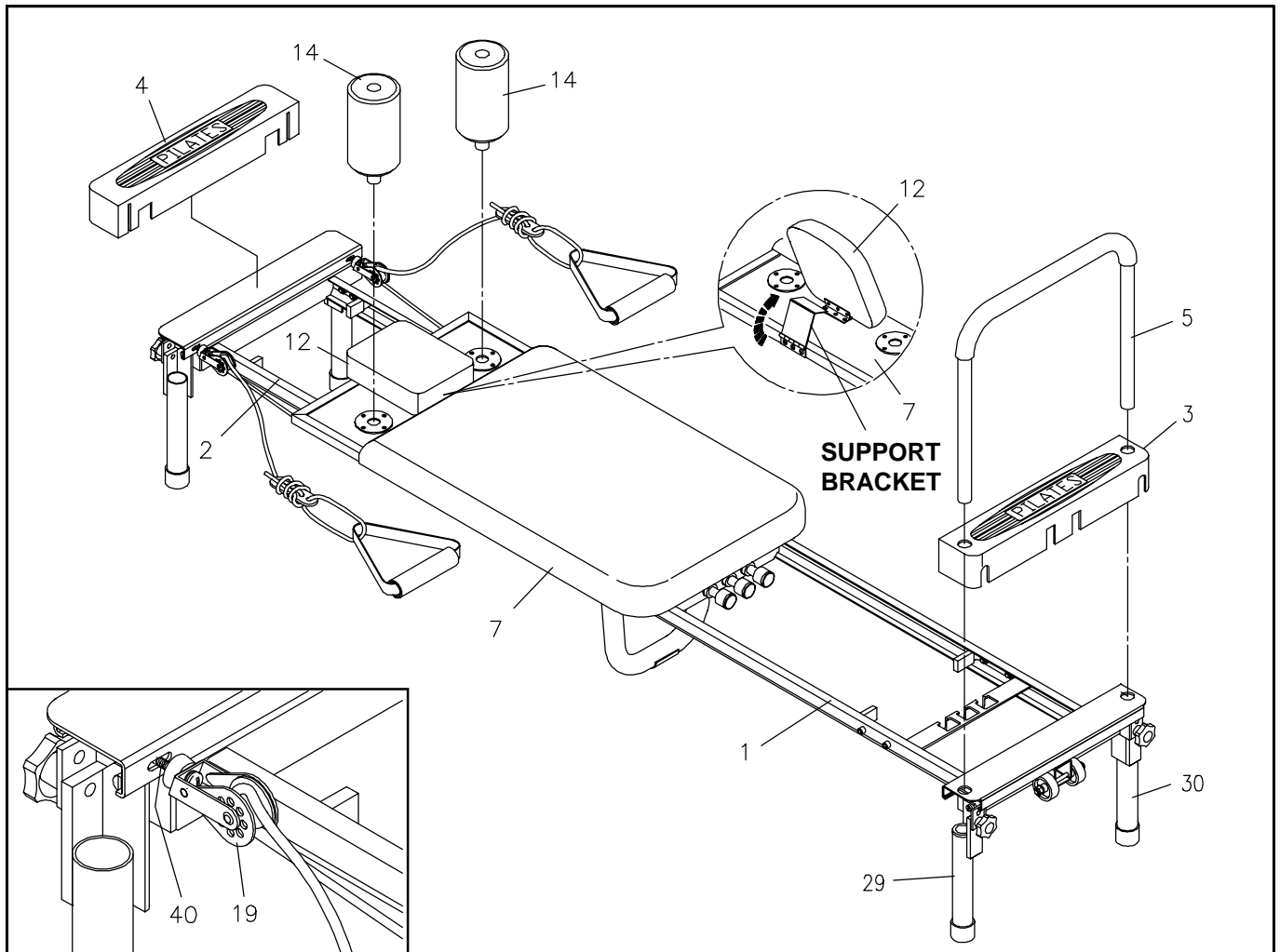

STEP 4

Remove the paper covering from the foam tape inside the **FRONT COVER(3)** and **REAR COVER(4)**. Place the **FRONT COVER(3)** over the **FRONT FRAME(1)**. Place the **REAR COVER(4)** over the **REAR FRAME(2)**. Press the covers securely in place.

NOTE: The securing **SCREWS(M6 x 35mm)(40)** for the **PULLEYS(19)** on each side may need to be loosened to allow the **REAR COVER(4)** to fit securely over the frame. Refer to illustration. When retightening the screws for the **PULLEYS(19)** do not over tighten. The **PULLEYS(19)** should move freely.

STEP 5

Insert the **FOOT REST(5)** into the mounting holes located on the **FRONT FRAME(1)**. The **FOOT REST(5)** should pass through the **FRONT COVER(3)** and the **FRONT FRAME(1)** and insert into the **LEGS(29, 30)**.

STEP 6

Insert the **FOAM PADS(14)** into the holes located on the **CUSHION ASSEMBLY(7)**. The **HEAD REST(12)** on the **CUSHION ASSEMBLY(7)** can be positioned at an incline by simply pivoting the **SUPPORT BRACKET** underneath the **HEAD REST(12)**.

ASSEMBLY INSTRUCTIONS

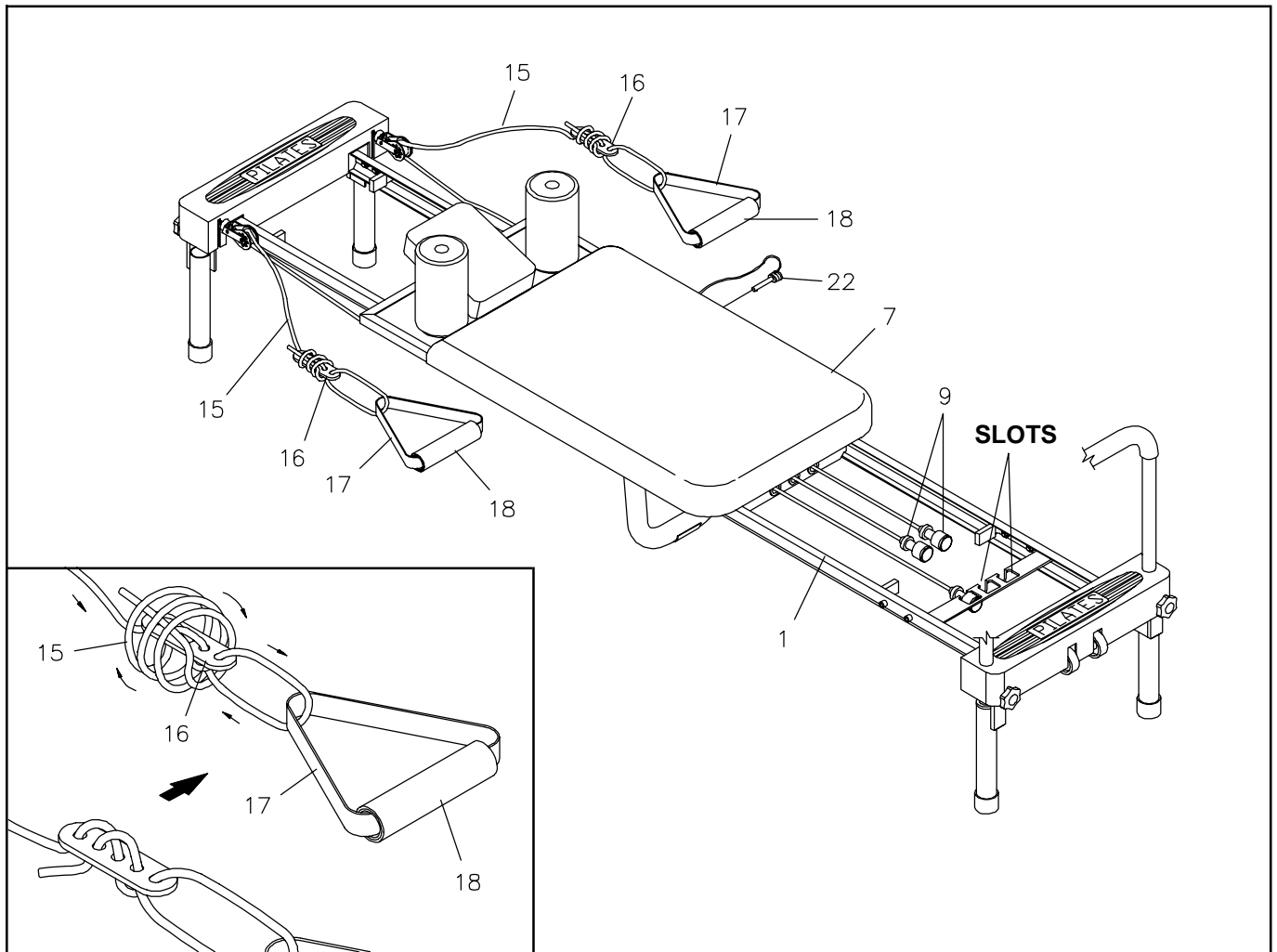

STEP 7

The resistance of the **CUSHION ASSEMBLY(7)** can be adjusted by securing the **TENSION CORDS(9)** in the slots located on the **FRONT FRAME(1)**. You can achieve various levels of resistance by securing different numbers of the **TENSION CORDS(9)** in the slots.

NOTE: 1. Remove the **LOCKING PIN(22)** which locks the **CUSHION ASSEMBLY(7)** in place before attaching the **TENSION CORDS(9)** to the slots.

2. To achieve greater resistance in the **TENSION CORDS(9)**, stretch and re-tie the tension cords in a more taut position.

STEP 8

The length on the **ROPE(15)** can be adjusted by pulling the **ROPE(15)** through the **ROPE ADJUSTMENT BRACKET(16)** as shown. Be sure to adjust both ropes to the same length. In addition to the **ROPE(15)**, the **HAND STRAP(17)** can be adjusted to accommodate your size and workout needs. If you find you need to adjust the **ROPE(15)** even more, wrap the excess **ROPE(15)** around the **ROPE ADJUSTMENT BRACKET(16)**. Refer to illustration.

USAGE INFORMATION

STORAGE

The **PILATES PERFORMER JP** can be folded as illustrated for easy storage. Please follow the following process:

1. Remove the **TENSION CORDS(9)** from the slots on the **FRONT FRAME(1)**. Move the **CUSHION ASSEMBLY(7)** back and lock it to the **REAR FRAME(2)** with the **LOCKING PIN(22)**.
2. Remove the **FOOT REST(5)** from the **FRONT FRAME(1)**. Set the **PILATES PERFORMER JP** on the floor on its side, with the **LOCKING PIN(22)** side upward. Make sure the **LOCKING PIN(22)** locks the **CUSHION ASSEMBLY(7)** properly. Fold the **MAIN FRAME ASSEMBLY** half way as shown in the illustration below.
3. Remove the **LOCKING KNOBS(27)** from the **FRONT** and **REAR FRAME(1, 2)**. Swing the **LEGS (29, 30)** into the folded position and screw the **LOCKING KNOBS(27)** into the threaded holes on the **FRONT** and **REAR FRAME(1, 2)**.
4. Remove the **LOCKING KNOBS(27)** from the **U SHAPED LEG(28)**. Swing the **U SHAPED LEG(28)** into the folded position and screw the **LOCKING KNOBS(27)** back into the **U SHAPED LEG(28)**.
5. Fold the **PILATES PERFORMER JP** as shown in the illustration.

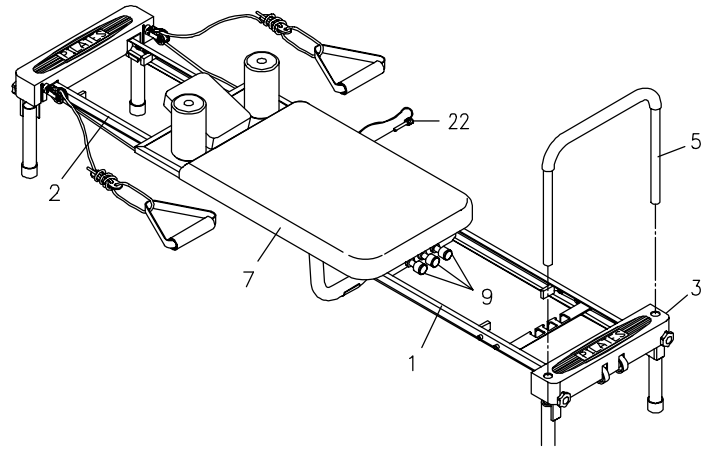

WARNING: When folding or unfolding the **PILATES PERFORMER JP**, keep all children away from the **PILATES PERFORMER JP** and make sure your hands are clear of any folding or pinch point.

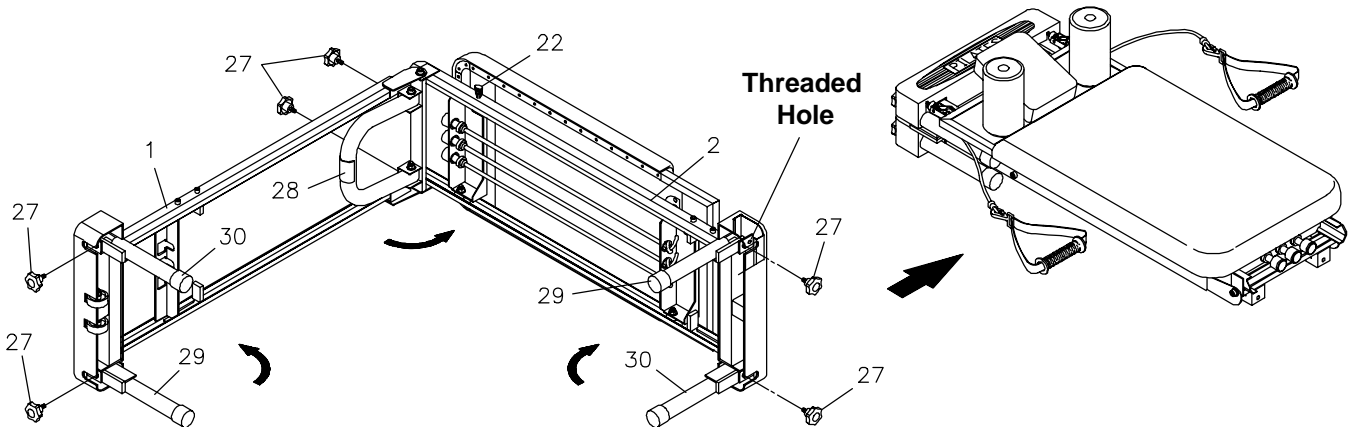

MOVING YOUR PILATES PERFORMER JP

There are two **WHEELS(21)** on the **FRONT FRAME(1)** for moving the **PILATES PERFORMER JP**.

Remove the **FOOTREST(5)** from the **FRONT FRAME(1)**. Remove the **LOCKING KNOBS(27)** and fold the two **LEGS(29, 30)** on the **FRONT FRAME(1)**. Now, you can lift the other end of the product to move it with the wheels.

NOTE: If the **LEGS(29, 30)** will not stay folded, tighten the **SHAFT BOLTS(35)**.

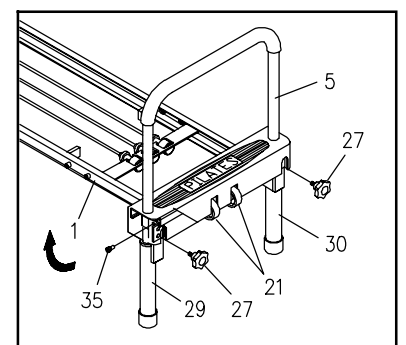

CONDITIONING GUIDELINES

How you begin your exercise program depends on your physical condition. If you have been inactive for several years, or are severely overweight, you must start slowly and increase your time on the **PILATES PERFORMER JP** gradually: a few minutes per workout.

Initially, you may be able to exercise only for a few minutes in your target zone, however, your aerobic fitness will improve over the next six to eight weeks. Don't be discouraged if it takes longer. It's important to work at your own pace. Ultimately, you'll be able to exercise continuously for 30 minutes. The better your aerobic fitness, the harder you will have to work to stay in your target zone. Please remember these essentials:

- Have your doctor review your training and diet programs to advise you of a workout routine you should adopt.
- Begin your training program slowly with realistic goals that have been set by you and your doctor.
- Monitor your pulse frequently. Establish your target heart rate base on your age and condition.
- Set up your **PILATES PERFORMER JP** on a flat, even surface at least 3 feet from walls and furniture.

EXERCISE INTENSITY

To maximize the benefits of exercising, it is important to exercise with the proper intensity. The proper intensity level can be found by using your heart rate as a guide. For effective aerobic exercise, your heart rate should be maintained at a level between 70% and 85% of your maximum heart rate as you exercise. This is known as your target zone. You can find your target zone in the table below. Target zones are listed for both unconditioned and conditioned persons according to age.

AGE	UNCONDITIONED TARGET ZONE (BEATS/MIN.)	CONDITIONED TARGET ZONE (BEATS/MIN.)
20	138~167	133~162
25	136~166	132~160
30	135~164	130~158
35	134~162	129~156
40	132~161	127~155
45	131~159	125~153
50	129~156	124~150
55	127~155	122~149
60	126~153	121~147
65	125~151	119~145
70	123~150	118~144
75	122~147	117~142
80	120~146	115~140
85	118~144	114~139

During the first few months of your exercise program, keep your heart rate near the low end of your target zone as you exercise. After a few months, your heart rate can be increased gradually until it is near the middle of your target zone as you exercise.

To measure your heart rate, stop exercising but continue moving your legs or walking around and place two fingers on your wrist. Take a six-second heartbeat count and multiply the results by 10 to find your heart rate. For example, if your six-second heartbeat count is 14, your heart rate is 140 beats per minute. (A six-second count is used because your heart rate will drop rapidly when you stop exercising.) Adjust the intensity of your exercise until your heart rate is at the proper level.

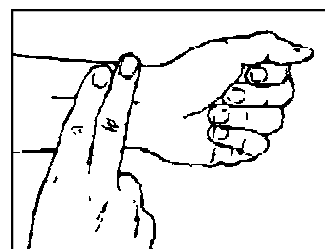

WARM-UP and COOL-DOWN

Warm-up The purpose of warming up is to prepare your body for exercise and to minimize injuries. Warm up for two to five minutes before strength-training or aerobic exercising. Perform activities that raise your heart rate and warm the working muscles. Activities may include brisk walking, jogging, jumping jacks, jump rope, and running in place

Stretching Stretching while your muscles are warm after a proper warm-up and again after your strength or aerobic training session is very important. Muscles stretch more easily at these times because of their elevated temperature, which greatly reduces the risk of injury. Stretches should be held for 15 to 30 seconds. Do not bounce.

Suggested Stretching Exercises



Lower Body Stretch

Place feet shoulder-width apart and lean forward. Keep this position for 30 seconds using the body as a natural weight to stretch the backs of the legs. **DO NOT BOUNCE!**

When the pull on the back of the legs lessens, try a lower position gradually.



Floor Stretch

While sitting on the floor, open the legs as wide as possible. Stretch the upper body toward the knee on the right leg by using your arms to pull your chest to your thighs. Hold this stretch 10 to 30 seconds. **DO NOT BOUNCE!** Do this stretch 10 times. Repeat the stretch with the left leg.

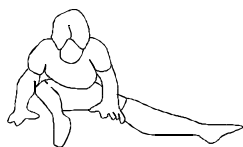

Bent Torso Pulls

While sitting on the floor, have legs apart one leg straight and one knee bent. Pull the chest down to touch the thigh on the leg that is bent and twist at the waist. Hold this position at least 10 seconds. Repeat 10 times on each side.

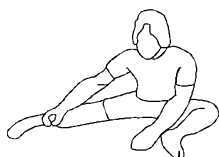

Bent Over Leg Stretch

Stand with feet shoulder-width apart and lean forward as illustrated. Using the arms, gently pull the upper body towards the right leg. Let the head hang down. **DO NOT BOUNCE!** Hold the position a minimum of 10 seconds. Repeat pulling the upper body to the left leg. Do this stretch several times slowly.

Remember always to check with your physician before starting any exercise program.

Cool-Down The purpose of cooling down is to return the body to its normal, or near normal, resting state at the end of each exercise session. A proper cool-down slowly lowers your heart rate and allows blood to return to the heart. Your cool-down should include the stretches listed above and should be completed after each strength-training session.

PRODUCT PARTS DRAWING

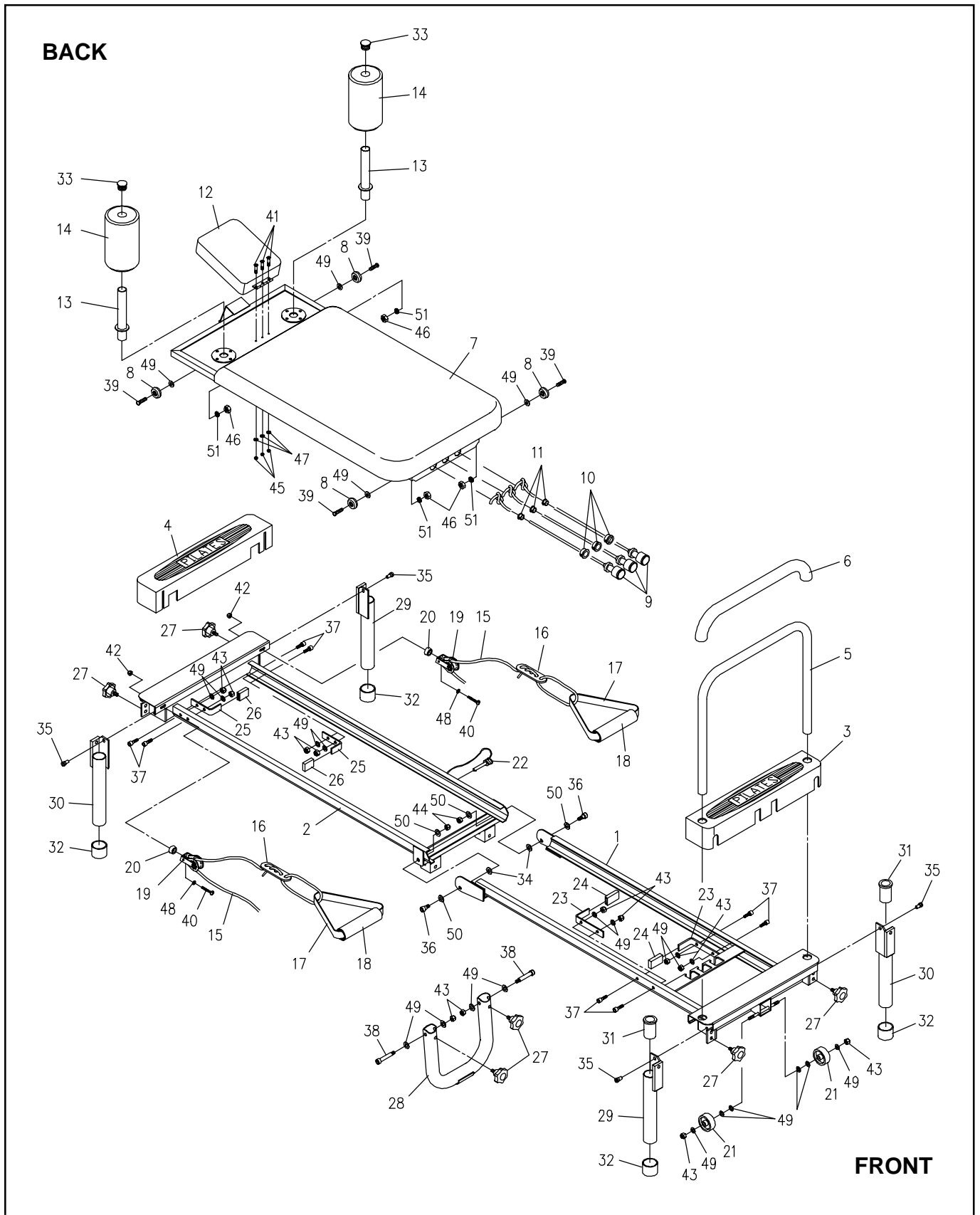

PARTS LIST

DIAGRAM#	PART NAME	QTY
1	Front Frame	1
2	Rear Frame	1
3	Front Cover	1
4	Rear Cover	1
5	Foot Rest	1
6	Foam Sleeve	1
7	Cushion Assembly	1
8	Cushion Assembly Roller	4
9	Tension Cord	3
10	Support Bushing	3
11	Stop Bushing	3
12	Head Rest	1
13	Foam Pad Tube	2
14	Foam Pad	2
15	Rope	2
16	Rope Adjustment Bracket	2
17	Hand Strap	2
18	Hand Grip	2
19	Pulley	2
20	Pulley Spacer	2
21	Wheel	2
22	Locking Pin	1
23	Stop Plate	2
24	Stop Pad	2
25	Small Stop Plate	2
26	Small Stop Pad	2
27	Locking Knob	6
28	U Shaped Leg	1
29	Leg A	2
30	Leg B	2
31	Leg Bushing	2
32	End Cap (38mm)	4
33	Round Plug (25mm)	2
34	Spacer (M10)	2
35	Shaft Bolt	4
36	Bolt, Socket Head (M10 x 1.5 x 20mm)	2
37	Bolt, Socket Head (M8 x 1.25 x 20mm)	8
38	Bolt, Socket Head (M8 x 1.25 x 60mm)	2
39	Bolt, Round Head (M8 x 1.25 x 25mm)	4
40	Screw, Round Head (M6 x 1 x 35mm)	2
41	Screw, Flat Head (M5 x 0.8 x 25mm)	3
42	Nylon Nut (M6 x 1)	2
43	Nylon Nut (M8 x 1.25)	12
44	Nylon Nut (M10 x 1.5)	2

PARTS LIST

DIAGRAM#	PART NAME	QTY
45	Nylon Nut (M5 x 0.8)	3
46	Nut (M8 x 1.25)	4
47	Washer (M5)	3
48	Washer (M6)	2
49	Washer (M8)	22
50	Washer (M10)	4
51	Lock Washer (M8)	4
52	Combination Wrench	1
53	Socket Wrench	1
54	Manual	1
55	Instruction Video	1
56	Workout Chart	1

WARRANTY

Stamina Products, Inc. warrants that this product will be free from defects in materials and workmanship under normal use, service and proper operation for a period of 90 days on the parts and three years on the frame from the date of the original purchase from an authorized retailer. **THIS WARRANTY SHALL NOT APPLY TO ANY PRODUCT WHICH HAS BEEN SUBJECT TO COMMERCIAL USE, ABUSE, MISUSE, ALTERATION OF ANY TYPE OR CAUSE OR TO ANY DEFECT OR DAMAGE CAUSED BY REPAIR, REPLACEMENT, SUBSTITUTION OR USE WITH PARTS OTHER THAN PARTS PROVIDED BY STAMINA PRODUCTS, INC.** Commercial use includes use of the product in athletic clubs, health clubs, spas, gymnasiums, exercise facilities, and other public or semipublic facilities whether or not the product's use is in furtherance of a profit making enterprise, and all other use which is not for personal, family, or household purposes.

To implement this limited warranty, send a written notice stating your name, date, and place of purchase and a brief description of the defect along with your receipt to **Stamina Products, Inc. P.O. Box 1071, Springfield Missouri, USA, 65801-1071** or call us at **1 (800) 375-7520**. If the defect is covered under this limited warranty, you will be requested to return the product or part to us for free repair or replacement at our option. **NO ACTION FOR BREACH OF THIS LIMITED WARRANTY MAY BE COMMENCED MORE THAN ONE (1) YEAR AFTER THE DATE THE ALLEGED BREACH WAS OR SHOULD HAVE BEEN DISCOVERED. NO ACTION FOR BREACH OF ANY IMPLIED WARRANTY MAY BE COMMENCED MORE THAN ONE (1) YEAR AFTER DELIVERY OF THE PRODUCT TO THE PURCHASER.** This limited warranty is not transferable. **IF ANY PART OF THE PRODUCT IS NOT IN COMPLIANCE WITH THIS LIMITED WARRANTY OR ANY IMPLIED WARRANTY, THE REMEDY OF REPAIR OR REPLACEMENT IS THE EXCLUSIVE REMEDY AVAILABLE TO YOU.** In the event that the purchaser makes any claim under this limited warranty or any implied warranty, the Warrantor reserves the right to require the product to be returned for inspection, at the purchaser's expense, to the Warrantor's premises in Springfield, Missouri. Return of the enclosed warranty registration card is not required for warranty coverage, but is merely a way of establishing the date and place of purchase.

Stamina Products, Inc. **SHALL NOT BE LIABLE FOR THE LOSS OF USE OF ANY PRODUCT, LOSS OF TIME, INCONVENIENCE, COMMERCIAL LOSS OR ANY OTHER INDIRECT, CONSEQUENTIAL, SPECIAL OR INCIDENTAL DAMAGES DUE TO BREACH OF THE ABOVE WARRANTY OR ANY IMPLIED WARRANTY.**

This limited warranty is the only written or express warranty given by Stamina Products, Inc. This warranty gives you specific legal rights, and you may also have other legal rights which vary from state to state. **ANY OTHER RIGHT WHICH YOU MAY HAVE, INCLUDING ANY IMPLIED WARRANTY OR MERCHANTABILITY OR FITNESS FOR A PARTICULAR PURPOSE, IS LIMITED IN DURATION TO THE DURATION OF THIS WARRANTY.**

The laws in some jurisdictions restrict the rights of manufacturers and distributors of consumer goods to disclaim or limit implied warranties and consequential and incidental damages with respect thereto. If any such law is found to be applicable, the foregoing disclaimers and limitations of and on implied warranties and consequential and incidental damages with respect thereto shall be disregarded and shall be deemed not to have been made to the extent necessary to comply with such legal restriction.

NOTES

NOTES

